

GV-NET/IO Card V3.1

The GV-NET/IO provides 4 inputs and 4 relay outputs. The new version of GV-NET/IO Card supports both DC and AC output voltages, and provides a USB port as well.

Key Features

- ❶ A USB port is provided for PC connection, and it is used with 30 DC output voltage.
- ❷ It can switch between two modes, NET/IO Card Mode and I/O Box Mode, which expands its capability.
- ❸ Up to 4 GV-NET/IO Cards can be chained together when it is in the I/O Box mode.
- ❹ It can act as an independent device when it is in the I/O Box mode.

Packing List

- | | |
|---|---------------------------------------|
| ❶ GV-NET I/O Card x1 | ❺ 3-Pin Internal USB Cable x 1 |
| ❷ 20-Pin Ribbon Cable (4 Connectors) x1 | ❻ 4-Pin to 4-Pin Mini Power Cable x 1 |
| ❸ RJ-11 to DB9 Cable x1 | ❼ Installation Guide x 1 |
| ❹ RJ-11 to USB Cable x 1 | |

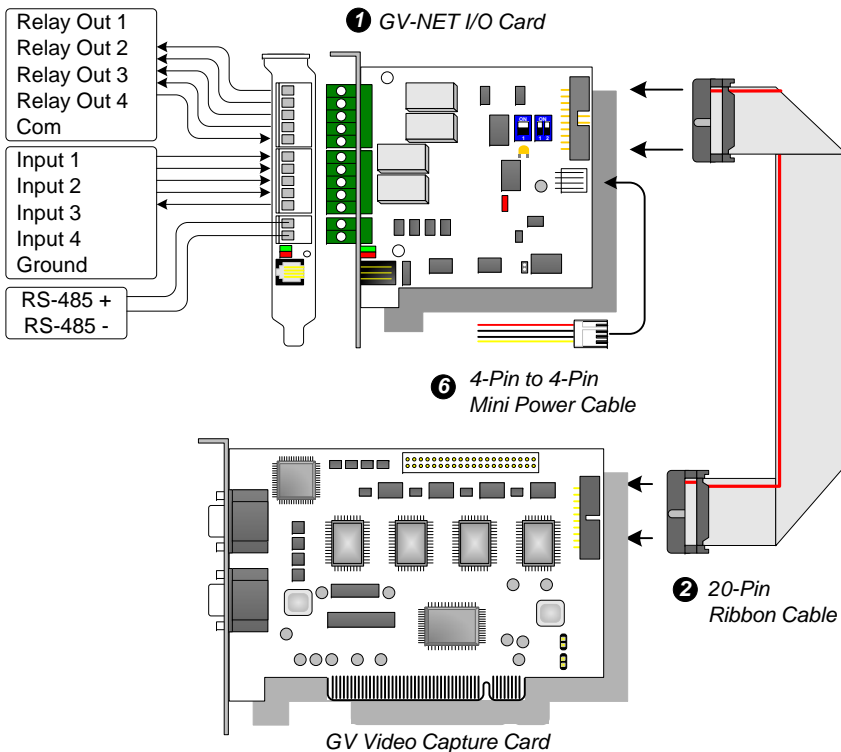

Specifications

Input	Input	4	
	Input Signal	Dry Contact Wet Contact: 9~30V AC/DC	
Output	Relay Output	4	
	Relay Status	Normal Open	
	Relay Capacitance	USB Connection	30V DC, 3A
		RS-232 Connection	125 / 250V AC, 3A 30V DC, 3A
Interface	RJ-11 to DB9		
	RJ-11 to USB		
	3-pin internal USB to internal USB		
Mode Switch	I/O Box Mode	Without GV Video Capture Card	
	NET/IO Card Mode	With GV Video Capture Card	
Address	1-4		
Communication	RS-485, USB, RS-232		
Environmental Conditions	0~50 degree C , 5%~95% (non-condensing)		
Dimensions (W) x (H)	99 x 90 (mm) / 3.9 x 3.54 (in)		

Important:

1. The supplied RJ-11 to DB9 Cable of older versions is not compatible with the GV-NET/IO Card V3.1.

Version 3.1
With a PC Mark

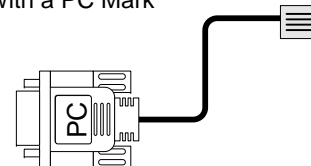

Older Versions
Without a PC Mark

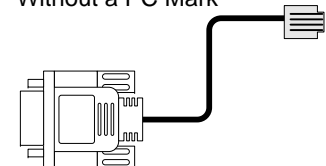

2. When the GV-NET/IO Card V3.1 is in the I/O Box mode, it is incompatible with the GV-IO 12-In Card of versions earlier than V3.

Connections In NET/IO Card Mode

For the connections in the NET/IO Card Mode, please follow the instructions below:

1. It is required to connect the GV-NET/IO Card to GV Video Capture Card with the 20-pin Ribbon Cable.
2. If you want to connect the GV-NET/IO Card to the RS-485 devices, you have 3 ways of connections. See the pictures below.

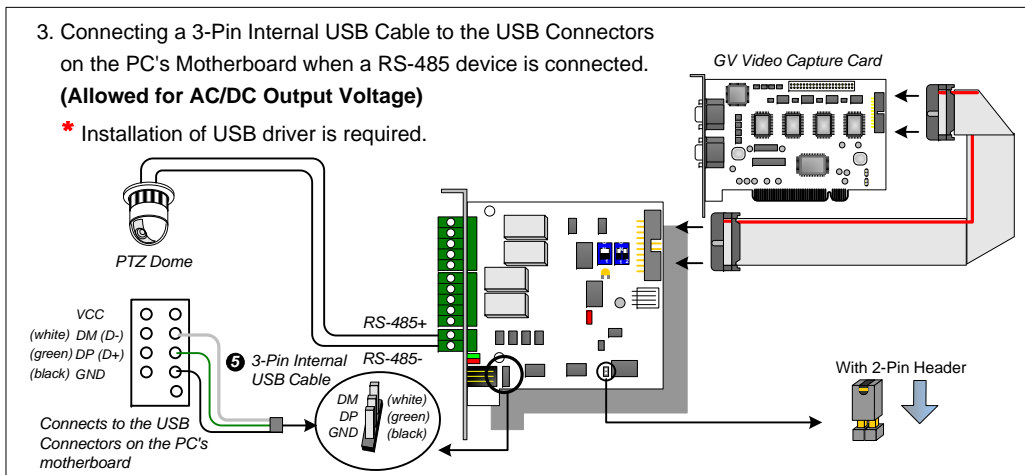
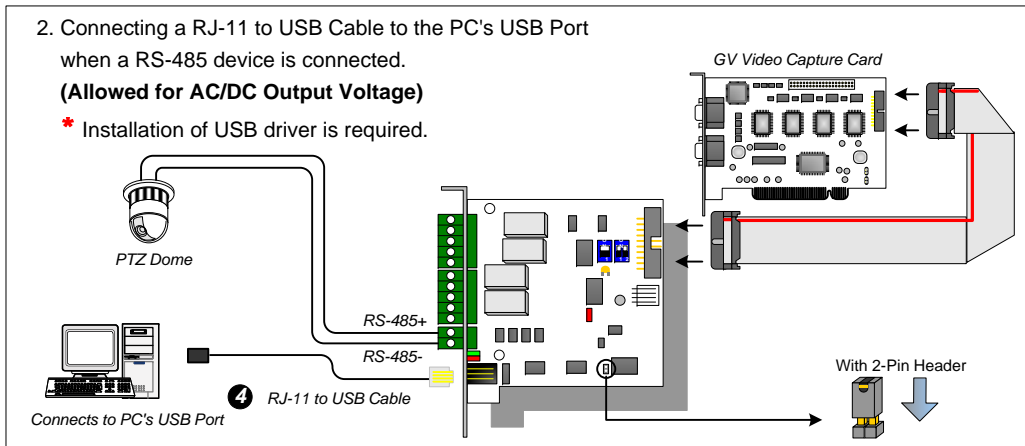
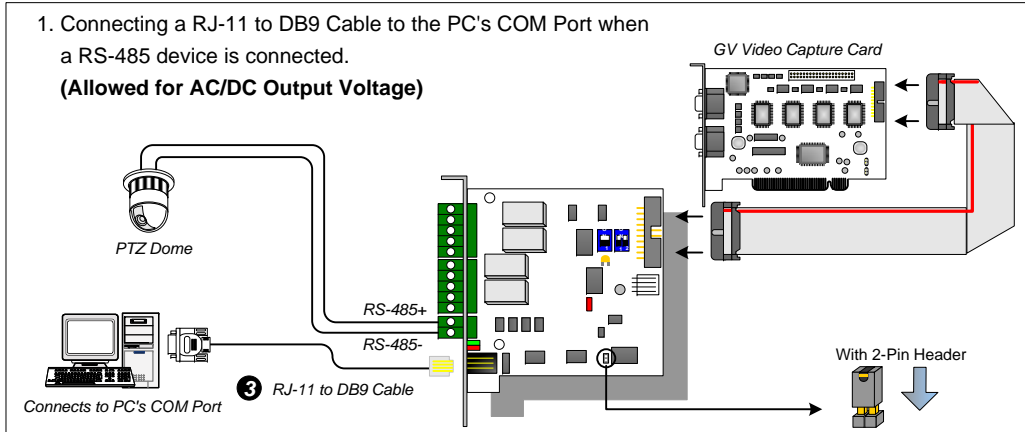

Connections In I/O Box Mode

For the connections in the I/O Box Mode, please follow the instructions below:

1. It is not necessary to connect the GV-NET/IO Card to GV Video Capture Card.
2. Connect the GV-NET/IO Card to the PC by one of the following 3 ways. See the pictures below.

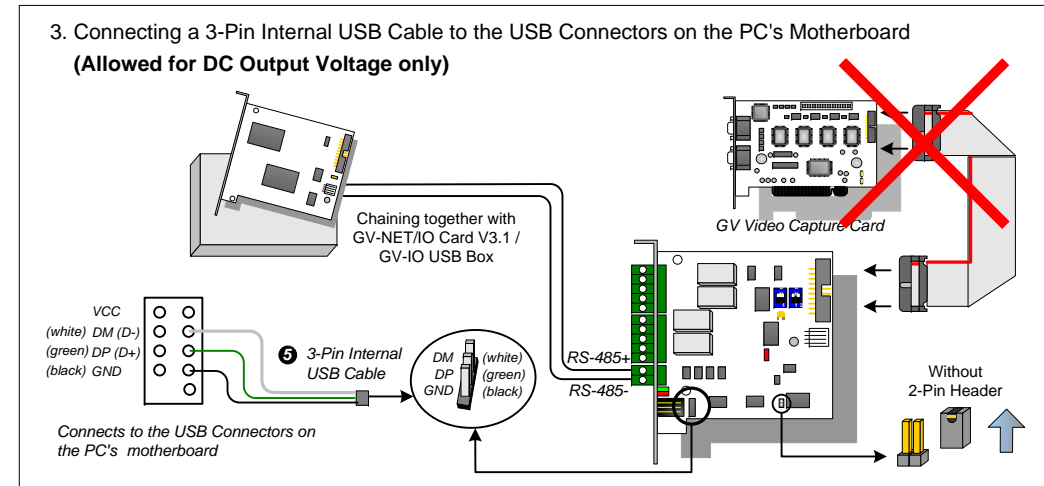
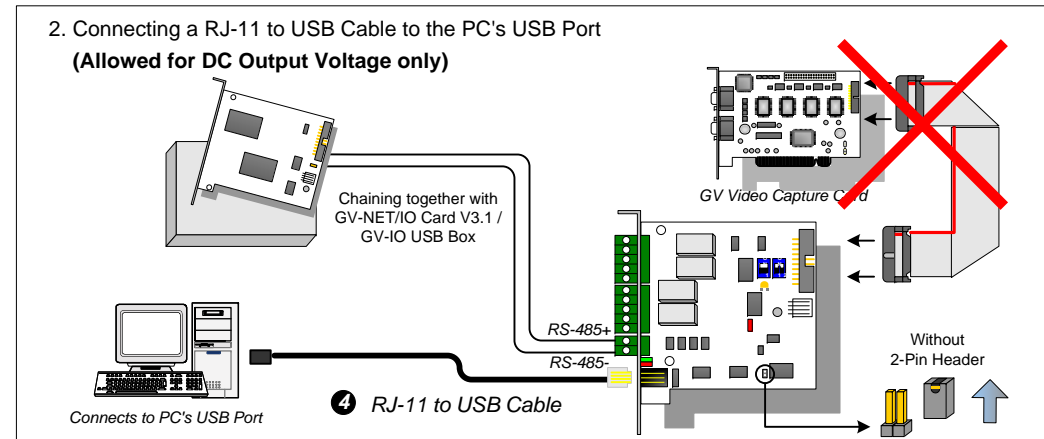
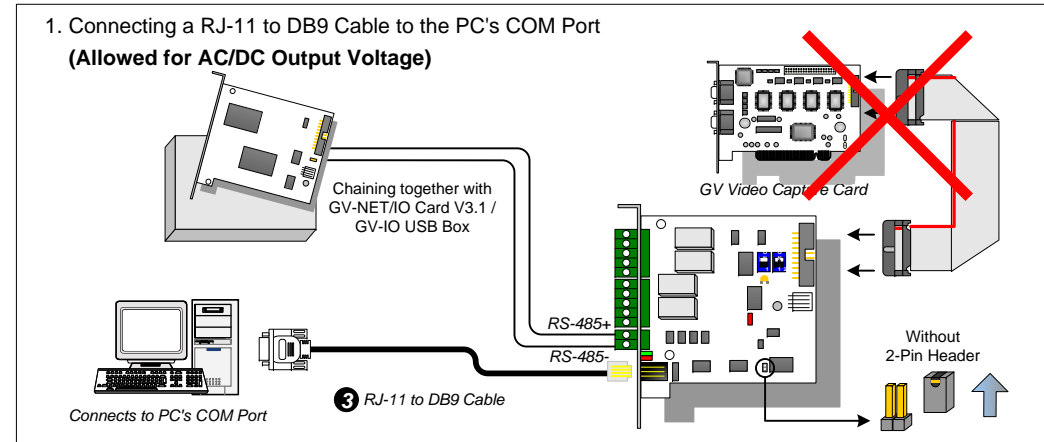

Switching Modes

The GV-NET/IO Card provides two modes for users to expand its capability: I/O Box Mode and NET/IO Card Mode. With a mode-switch jumper to insert on the 2-pin header, you can switch between modes.

NET/IO Card Mode (default): With the switch jumper inserted, this default mode acts as a GV-NET/IO Card. It is required to connect the GV-NET/IO Card to the GV Video Capture Card for usage.

I/O Box Mode: Without the switch jumper inserted, the GV-NET/IO Card can work as an independent device. It is NOT necessary to connect to the GV Video Capture Card for usage.

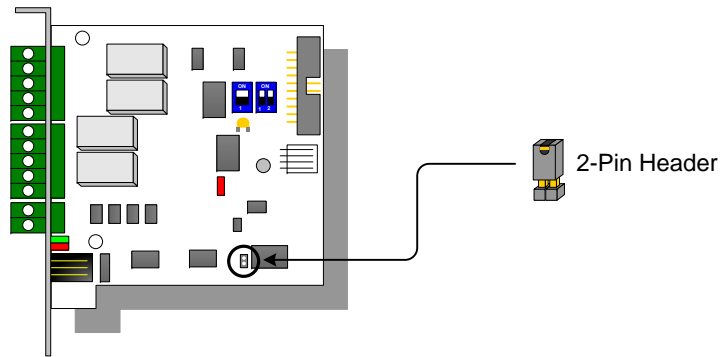

DIP Switch

The GV-NET/IO Card accepts input devices of dry contact or wet contact. Use the switch to change to dry contact and 9~30V wet contact.

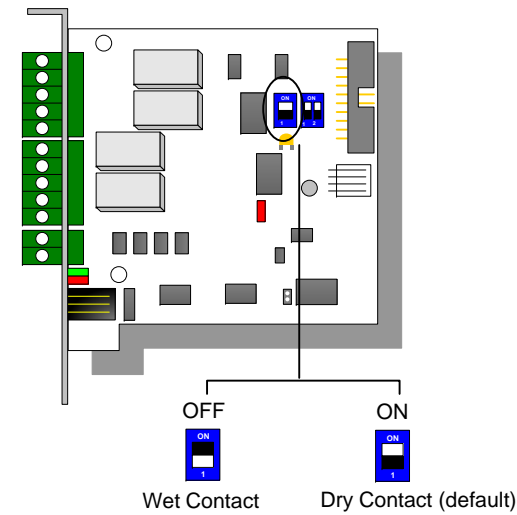

Extended Connections

Via the RS-485 connectors, up to 4 GV-NET/IO Cards can be chained together when the GV-NET/IO Card is on the I/O Box mode. For extended connections, the address assignment is shown below.

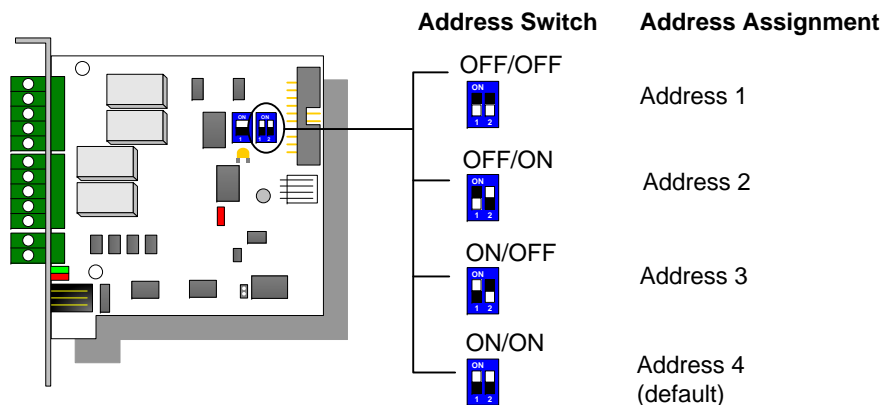

NOTE: When the GV-NET/IO Card is set to the I/O Box Mode, it can have extended connections with GV-I/O Boxes.

Caution: To prevent the noise interference in I/O operation, tightly screw the GV-NET/IO Card to the PC case.

USB Driver Installation

To use the USB function, it is required to install the driver on the PC. Follow these steps to install the driver:

- (1) Insert the software CD. It will run automatically and pop up a window.
- (2) Select **Install or Remove GeoVision GV-Series Driver** and then click **Install GeoVision USB Devices Driver**. This dialog box appears.

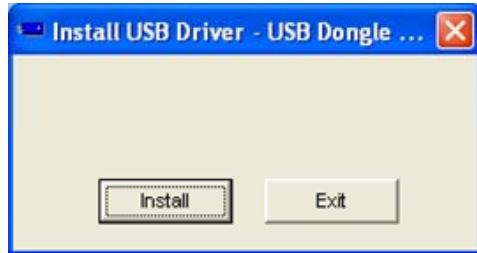

- (3) Click **Install** to install the drivers. When the installation is complete, this message will appear: *Install done!*
- (4) Click **Exit** to close the dialog box.
- (5) To verify the drivers are installed correctly, go to Device Manager. Expanding the Ports field, you should see one entry for Profile USB-to-Serial Bridge.

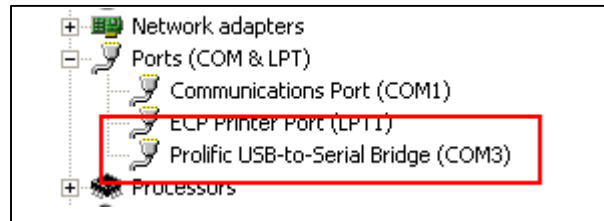

Connections with Two Video Capture Cards

In the computer where two GV Video Capture Cards are installed, the Cards of channels 1 to 16 and channels 17 to 32 are separately defined as the Master Card and the Slave Card. The GV-NET/IO Card should only connect to the Master GV Video Capture Card. Use the supplied Ribbon Cable to connect the GV-NET/IO Card to the Master Card.

